

混合式步进电机规格书

HYBRID STEPPING MOTOR SPECIFICATION

版本 REV.	位置 LOC.	变更号 ECN NO.	变更内容 REVISION RECORD	日期 DATE	设计 BY

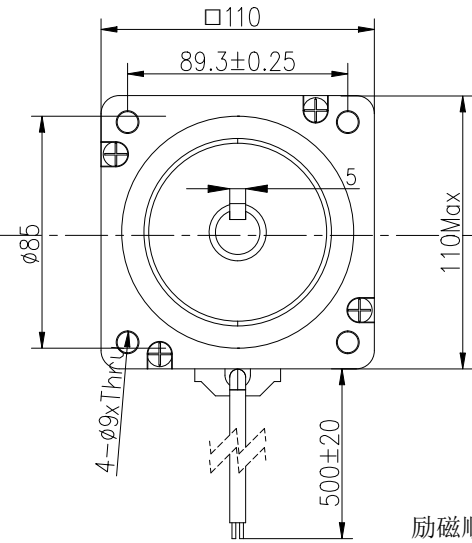
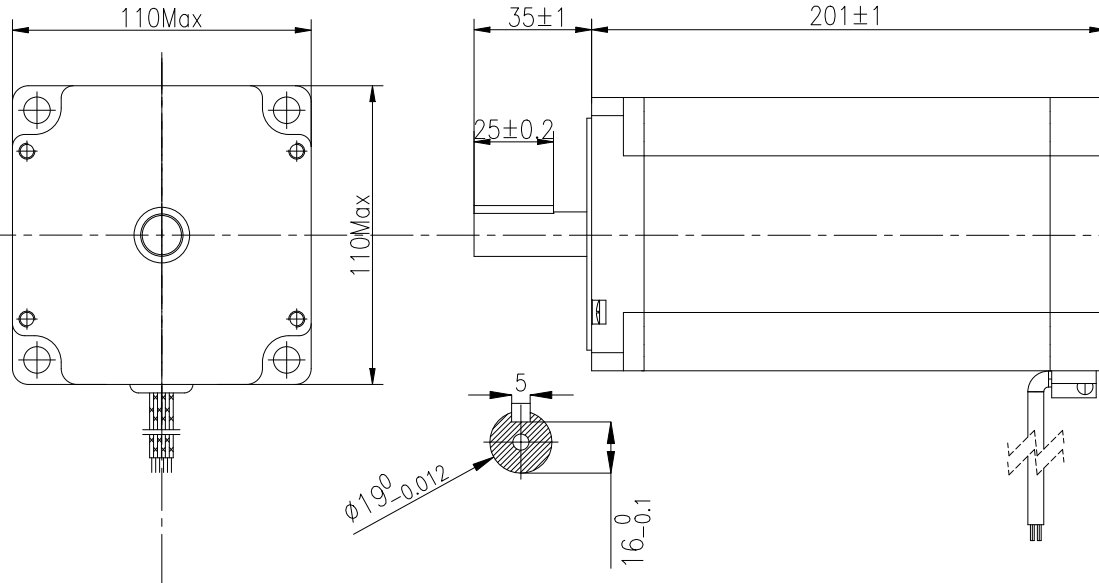

电机接线 Motor Wiring Diagram

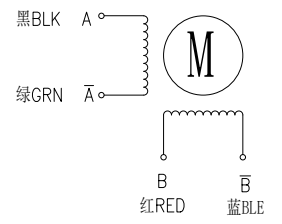

励磁顺序 & 旋转方向 从电机的安装面看
Excitation sequence & direction of rotation Viewed from the mounting surface of the motor

STEP	A	B	\bar{A}	\bar{B}	旋转方向
黑 BLK	+	+	-	-	CCW
绿 GRN	-	+	+	-	CCW
红 RED	-	-	+	+	CCW
蓝 BLE	+	-	-	+	CCW

电机相数/Phase	2
步距角/Step Angle	1.8°
额定电流/Rated current	6.0A
电阻/Resistance	1.0 Ω ±10%
电感/Inductance	20mH ±20%
静扭矩/Holding Torque	28N.m
绝缘耐压/Dielectric strength	500VAC/1min
绝缘电阻/Insulation Resistance	100M Ω Min/500VDC
转动惯量/Moment of inertia	1620kg.mm ²
温升/Temperature rise	80°C
电机重量/Motor mass	12kg
绝缘等级/Insulation class	B
防护等级/Protective enclosure rating	IP54

CTQ Sign: Customer; Process; Law	名称 NAMES	签名 SIGNATURE	日期 DATE	名称 TITLE	STEPPING MOTOR
物料符合RoHS指令要求 All Material are to be RoHS Compliant	设计 DESIGN			型号 MODEL	110HB201F6-19J
UNLESS OTHERWISE SPECIFIED	标准化 STANDARD			图号 DWG.NO.	
单位 Unit:mm <=6 ±0.1 >6~30 ±0.2 >30~120 ±0.3 ISO 2768-1 class m	工艺 TECHNOLOGY			日期 DATE	2025.05.02
2.常规公差Tolerances: 角度 Angles:±0.1° 倒角Chamfer:±5°	审核 CHECK			材料 MATERIAL	
	批准 APPROVE			图幅 SIZE	版本 REV. 页 SHEET 比例 SCALE
CHANGZHOU HOLRY ELECTRIC TECHNOLOGY CO.,LTD.	第一角画法 FIRST ANGLE METHOD	客户型号 CUSTOMER'S MODEL.NO.	版本 REV.		
	变更标识 ECN SIGN				