

User's Manual for DM422



Catalogue

1. Description
2. Application
3. Features
4. Specifications
5. Dimension Diagram
6. Current Setting
7. MicroStep Setting & Speed(I/O Mode) Setting
8. Terminal Function
9. Control Signal Circuit
10. Connections to 4-lead Motors
11. ALM CODE(Protection Functions)
12. Problem Symptoms and Possible Causes

1. Description

The DM422 is fully digital 2-phase Stepping Driver based on ARM control , the Driver voltage ranges from 18VDC~48VDC. It is designed for use with the 2-phase hybrid stepper motor of all kinds with 20mm to 42mm outside diameter, regulated phase current from 0.3A to 2.2A. The circuit that it adopts is similar to the circuit of servo control which enables the motor run smoothly without noise and vibration.

2. Application

It can be used in various kinds of machines, such as laser cutters, laser markers, high precision X-Y tables, labeling machines, and so on. Its unique features make the DM856 an ideal solution for applications that require both low-speed smoothness and high speed performances.

3. Features

- 16 channels constant angle, constant torque micro steps, highest micro step: 51200 steps/rev;
- Highest response frequency: 200KHz ;
- Support PUL/DIR and CW/CCW modes;
- Current of winding will be reduced by approximately 50% when no step pulse command is received for 1.5 seconds ;
- Opto-isolated Signal I/O ;
- Drive current is adjustable in 8 channels from 0.3A/phase to 2.2A/phase ;
- Single power supply from Single power supply from 18VDC to 48VDC ;
- Better to overcome the problem of low frequency vibration;
- Over-voltage, over-current, phase-error protections
- Dimension:93×56×21 mm; Net Weight: 111g.

4. Specifications

Electrical Specifications (Tj = 25°C/77°F)

Parameters	Min	Typical	Max	Unit
Output current	0.3	-	2.2	A
Supply voltage (VDC)	+18	24	+48	Vdc
Logic signal current	7	10	20	mA
Pulse input frequency	0	-	200	kHz
Isolation resistance	500			MΩ

5. Dimension Diagram (unit mm)

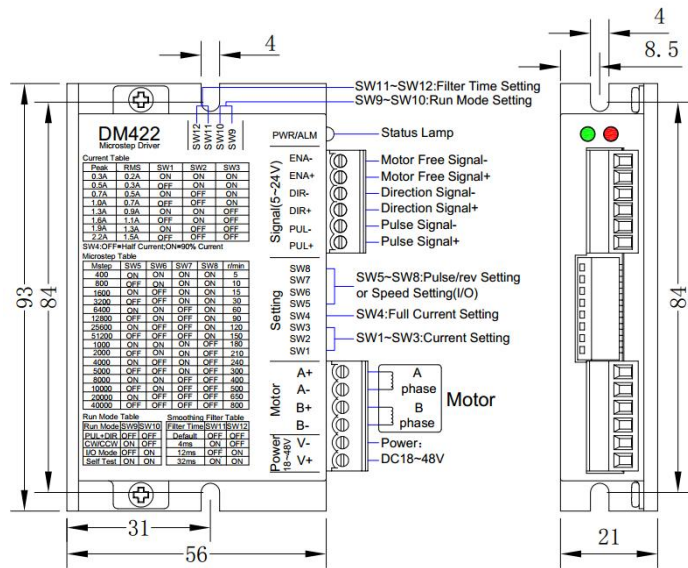

Figure 1: Mechanical specifications

6. Current Setting

The first three bits (SW1, SW2, SW3) of the DIP switch are used to set the dynamic current. Select a setting closest to your motor's required current. The current shows in the following table:

Peak Current	RMS Current	SW1	SW2	SW3
0.3A	0.2A	ON	ON	ON
0.5A	0.3A	OFF	ON	ON
0.7A	0.5A	ON	OFF	ON
1.0A	0.7A	OFF	OFF	ON
1.3A	0.9A	ON	ON	OFF
1.6A	1.1A	OFF	ON	OFF
1.9A	1.3A	ON	OFF	OFF
2.2A	1.5A	OFF	OFF	OFF

SW4: OFF=Half Current, ON=Full Current

7. MicroStep Setting & Speed (Speed Mode) Setting

The MicroStep and Speed is set by SW5, SW6, SW7, SW8 of the DIP switch as shown in the following table:

Pulse/rev	SW5	SW6	SW7	SW8	Speed (r/min)
400	ON	ON	ON	ON	5
800	OFF	ON	ON	ON	10
1600	ON	OFF	ON	ON	15
3200	OFF	OFF	ON	ON	30
6400	ON	ON	OFF	ON	60
12800	OFF	ON	OFF	ON	90
25600	ON	OFF	OFF	ON	120
51200	OFF	OFF	OFF	ON	150
1000	ON	ON	ON	OFF	180
2000	OFF	ON	ON	OFF	210
4000	ON	OFF	ON	OFF	240
5000	OFF	OFF	ON	OFF	300
8000	ON	ON	OFF	OFF	400
10000	OFF	ON	OFF	OFF	500

20000	ON	OFF	OFF	OFF	650
40000	OFF	OFF	OFF	OFF	800

Run Mode Setting Table

Run Mode	SW9	SW10
Single Pulse mode:PUL+DIR	OFF	OFF
Double pulse mode:CW/CCW	ON	OFF
I/O mode (Speed Mode)	OFF	ON
Self Test (± 30 r/min)	ON	ON

Speed Mode Setting Table

PUL	DIR	Instruction
1	1	Stop Rotation
1	0	Clock Wise Rotation (CW)
0	1	Counter Clock Wise Rotation (CCW)
0	0	Stop Rotation

Smoothing Filter Table

Filter Time	SW11	SW12
Default	OFF	OFF
4ms	ON	OFF
12ms	OFF	ON
32ms	ON	ON

8. Terminal Function

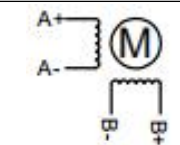
Pin function	Details
PUL+	Pulse signal: In single pulse (pulse/direction) mode, this input represents pulse signal, each rising or falling edge active (software configurable); 5-24V when PUL-HIGH, 0-0.5V when PUL-LOW. In double pulse mode (pulse/pulse), this input represents clockwise (CW) pulse. For reliable response, pulse width should be longer than 2.5 μ s.
PUL-	
DIR+	DIR signal: In single-pulse mode, this signal has low/high voltage levels, representing two directions of motor rotation; in double-pulse mode, this signal is counter-clock (CCW) pulse. For reliable motion response, DIR signal should be ahead of PUL signal by 5 μ s at least. 5-24V when DIR-HIGH, 0-0.5V when DIR-LOW. Please note that rotation direction is also related to motor-Drive wiring match. Exchanging the connection of two wires for a coil to the Drive will reverse motion direction.
DIR-	
ENA+	Enable signal: This signal is used for enabling/disabling the Drive. High level (NPN control signal, PNP and Differential control signals are on the contrary, namely Low level for enabling.) for enabling the Drive and low level for disabling the Drive. Usually left UNCONNECTED (ENABLED).
ENA-	
V+	Power supply: DC18~48V
V-	
A+, A-	Motor Coil: 
B+, B-	

9. Control Signal Circuit

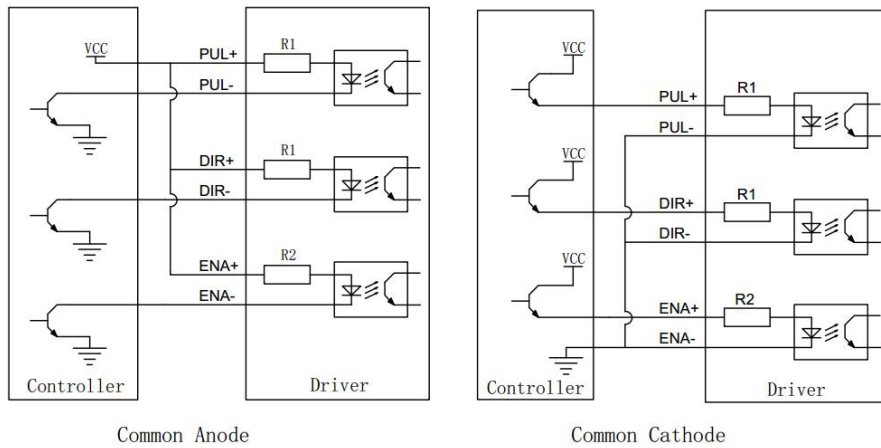

Figure 2: Control signal Interface Connection Diagram

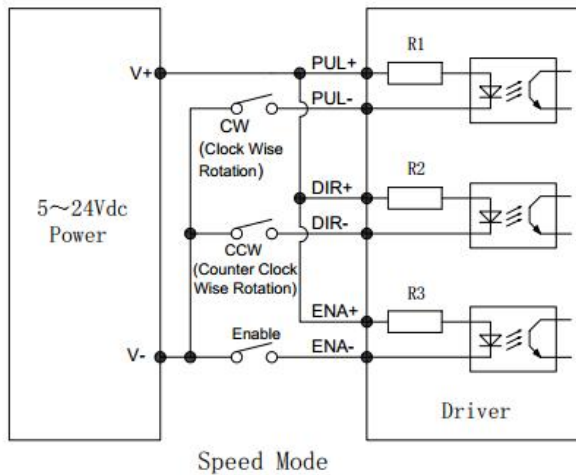

Figure 3: Speed mode connection

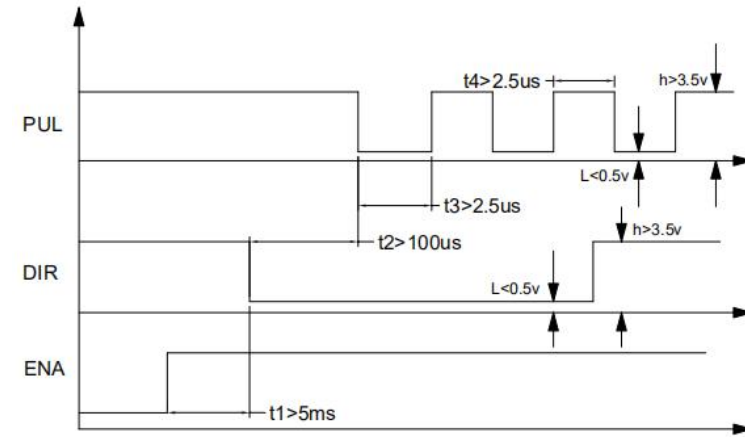

Figure 4: Sequence chart of control signals

Attention:

- t1: ENA must be ahead of DIR by at least 5ms. Usually, ENA+ and ENA- are NC (not connected).
- t2: DIR must be ahead of PUL active edge by 100 μ s to ensure correct direction;
- t3: Pulse width not less than 2.5 μ s;
- t4: Low level width not less than 2.5 μ s.

10. Connections to 4-lead Motors

4 lead motors are the least flexible but easiest to wire. Speed and torque will depend on winding inductance. In setting the Drive output current, multiply the specified phase current by 1.4 to determine the peak output current.

11. ALM CODE (Protection Functions)

To improve reliability, the Driver incorporates some built-in protection functions. The DM422 uses one RED LED to indicate what protection has been

activated. The periodic time of RED is 2 seconds, and how many times the RED turns on indicates what protection has been activated. Because only one protection can be displayed by RED LED, so the Drive will decide what error to display according to their priorities. See the following Protection Indications table for displaying priorities.

RED LED Twinkle Times	Alarm indicator
1	Over current protection (short circuit between motor coils or between motor coil and ground)
5	Over Voltage protection (48VDC)
8	No motor connected or poor connection (phase error protection)

12. Problem Symptoms and Possible Causes

Symptoms	Possible Problems
Motor is not rotating	No power
	Microstep resolution setting is wrong
	DIP switch current setting is wrong
	Fault condition exists
	The Drive is disabled
Motor rotates in the wrong direction	Motor phases may be connected in reverse
The Driver in fault	DIP switch current setting is wrong
	Something wrong with motor coil
Erratic motor motion	Control signal is too weak
	Control signal is interfered
	Wrong motor connection
	Something wrong with motor coil Current setting is too small, losing steps

Motor stalls during acceleration	Current setting is too small
	Motor is undersized for the application
	Acceleration is set too high
	Power supply voltage too low
Excessive motor and Drive heating	Inadequate heat sinking / cooling
	Automatic current reduction function not being utilized
	Current is set too high