



MOTIONtek

Leader Harmonious Drive Systems Co.,Ltd
TEL :0086- 512-66362298/66560692
FAX :0086- 512-66362325
E-mail : sales@leaderdrive.com
Add : No. 19 Muxu west Road,Mudu,Suzhou,P.R.China
Postal Code : 215101
<http://www.leaderdrive.com>



NO. LD2019-1-Y

®
Leaderdrive

leaderdrive®

苏州绿的谐波传动科技股份有限公司

Leader Harmonious Drive Systems Co.,Ltd

LHSG High-Torque Hollow-Shaft Flexspline
Strain Wave Gear
Product Introduction Manual



Ordering Code

Abbreviation for company

Length Code of Flexspline

Reduction Ratio

Structure Code

Code	Length
S	Standard
D	Dwarf

Note:
 1.30 50 80 100 120 160 are general reduction ratio
 2.Reduction ratio can be designed according to customer's demand

Code	Structure
C	Complete type
P	Component type
CL	Light weight of complete type

L C S G — 14 ——— 50 — C — II

Shape Code of Flexspline

Torque Code of Model

P.D.D of Flexible Gear

Connection Type

Code	Shape
C	Cup
H	Hollow

Code	Torque
G	High
null	Normal

Code	PDD (mm)
14	35.6
17	43.2
20	50.8
25	63.5
32	81.3
40	102
50	127
58	147

Code	Type
I	Standard type
II	Cross slipper type coupling
III	Hollow shaft type
IV	Shaft input type

LHSG-I series



LHSG-I series are high-torque models which have the same structure, with LHS-I series. However, their torque bearing capacity is improved by 30% compared with LHS series.

Parameter Table

Item	Reduction Ratio	Rated Torque at 2000r/min	Allowable Peak Torque at Start and Stop	Allowable Average Torque	Allowable Maximum Momentary Torque	Maximum Input Speed	Allowable Average Input Speed	Back lash	Weight	Design Life
		Nm	Nm	Nm	Nm	r/min	r/min	Arc sec	Kg	Hour
14	50	6.6	23	8.6	43	8000	3500	≤10	0.38	10000
	80	9.6	29	13.5	57			≤10		15000
	100	9.6	34	13.5	66			≤10		15000
17	50	19.8	42	32	86	7000	3500	≤10	0.56	10000
	80	27.5	53	33	108			≤10		15000
	100	30	66	49	134			≤10		15000
	120	30	66	49	107			≤10		15000
20	50	32	69	42	121	6000	3500	≤10	0.76	10000
	80	42	91	68	158			≤10		15000
	100	50	102	61	182			≤10		15000
	120	50	108	61	182			≤10		15000
	160	50	113	61	182			≤10		15000
25	50	48	121	68.5	230	5500	3500	≤10	1.24	10000
	80	78	169	107	315			≤10		15000
	100	84	194	133	351			≤10		15000
	120	84	207	133	376			≤10		15000
	160	84	217	133	388			≤10		15000
32	50	94	267	133	472	4500	3500	≤10	2.6	10000
	80	146	375	206	702			≤10		15000
	100	169	411	267	800			≤10		15000
	120	169	436	267	848			≤10		15000
	160	169	459	267	848			≤10		15000
40	50	169	497	242	847	4000	3000	≤10	5.0	10000
	80	255	641	351	1210			≤10		15000
	100	328	702	460	1334			≤10		15000
	120	363	762	557	1458			≤10		15000
	160	363	800	557	1458			≤10		15000
50*	80	459	1163	642	2297	3000	2500	≤10	9.5	15000
	100	580	1211	823	2545			≤10		15000
	120	654	1334	1005	2545			≤10		15000
	160	654	1468	1042	3025			≤10		15000
58*	80	678	1828	951	3026	3000	2200	≤10	13.6	15000
	100	860	1964	1309	3927			≤10		15000
	120	921	2124	1470	4113			≤10		15000
	160	921	2722	1494	4236			≤10		15000

* Consult factory

LHSG-I Series Drawings

LHSG-14-XXX-C-I

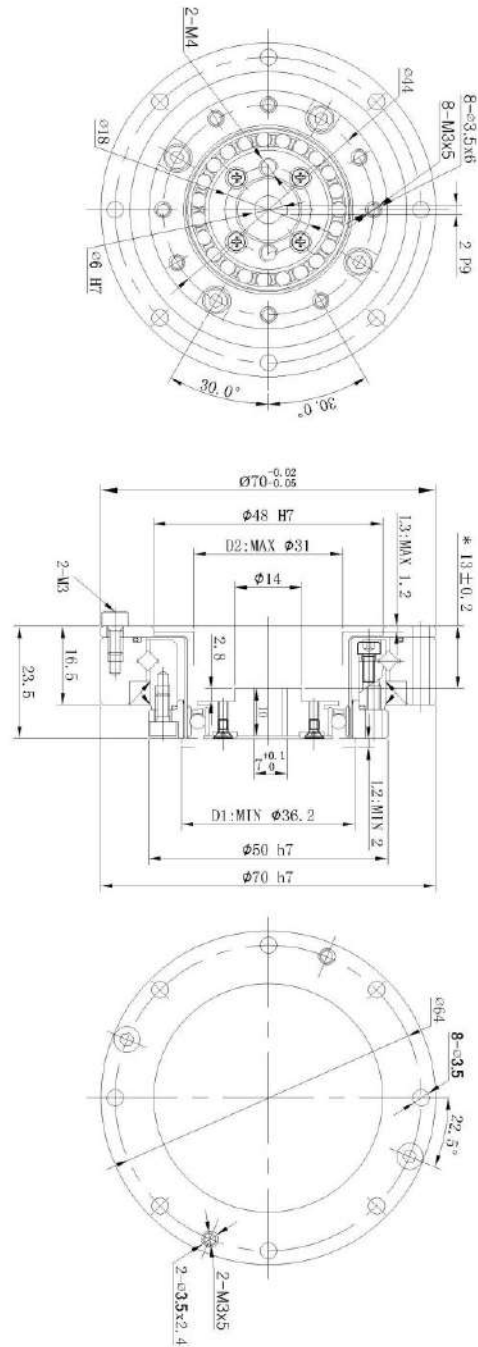

LHSG-17-XXX-C-I

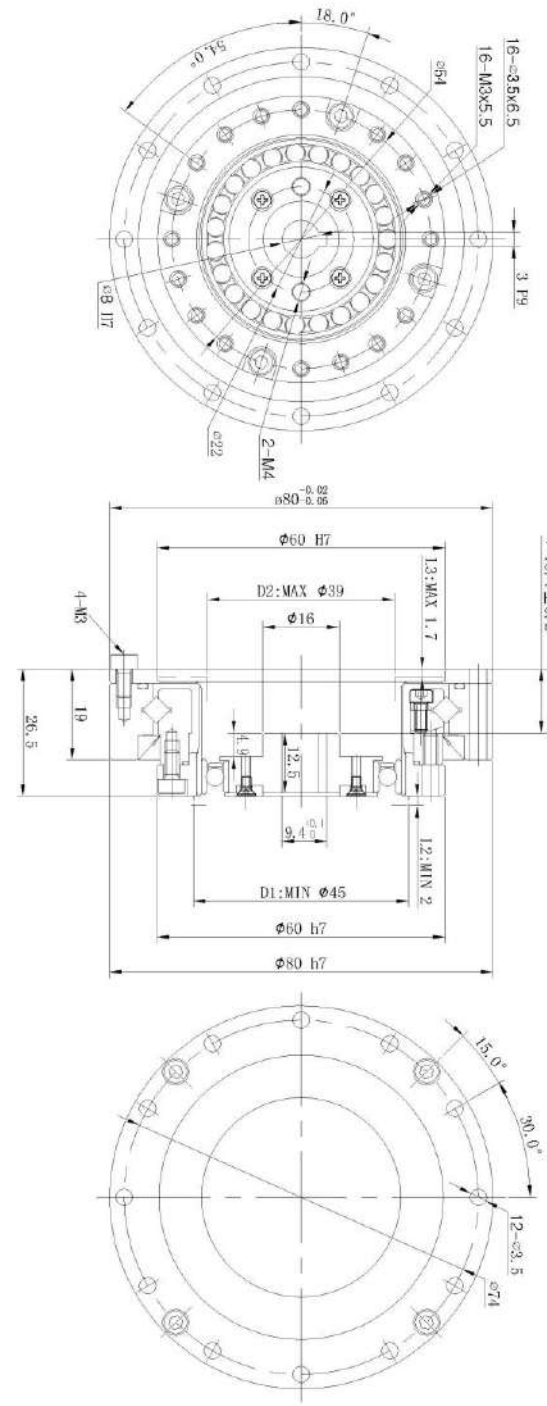

LHSG-I Series Drawings

LHSG-20-XXX-C-I

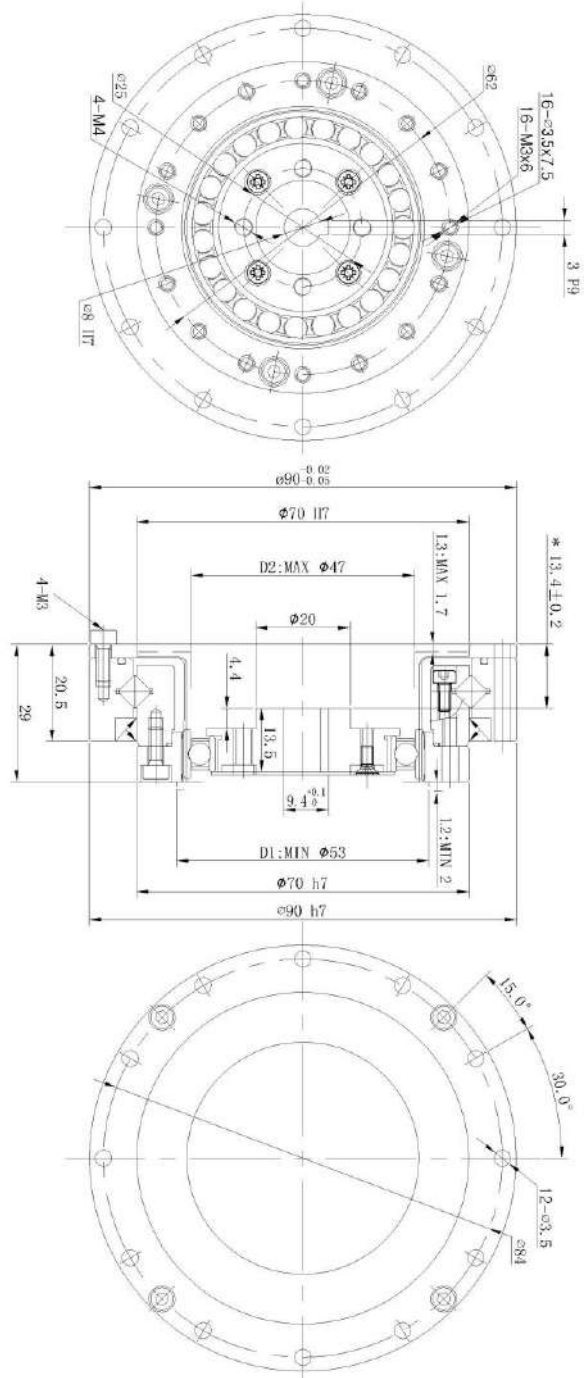

LHSG-25-XXX-C-I

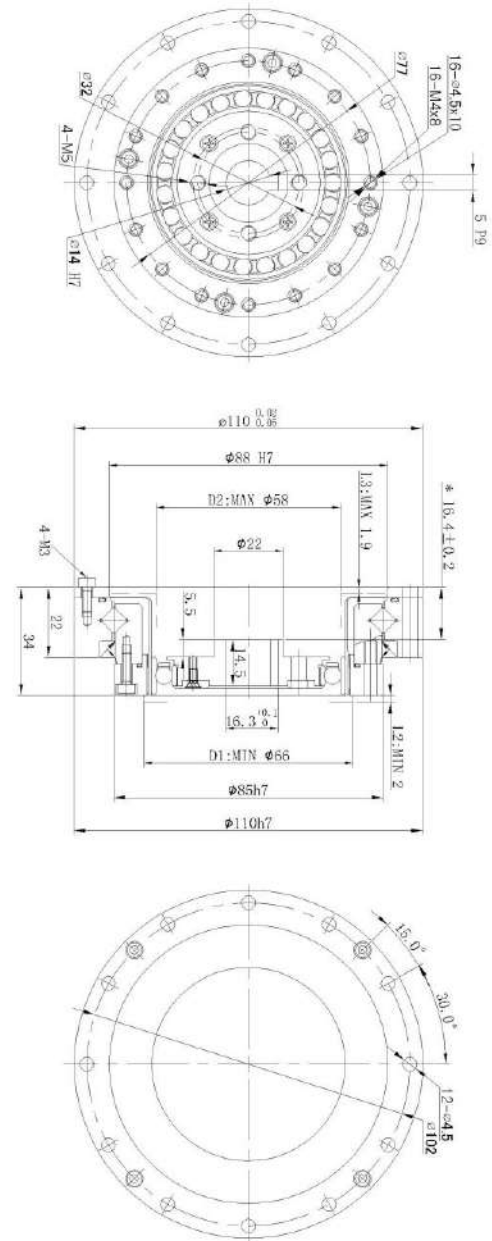

LHSG-II series



LHSG-II series are high-torque models which have the same structure, with LHS-II series. However, their torque bearing capacity is improved by 30% compared with LHS series.

Parameter Table

Item	Reduction Ratio	Rated Torque at 2000r/min	Allowable Peak Torque at Start and Stop	Allowable Average Torque	Allowable Maximum Momentary Torque	Maximum Input Speed	Allowable Average Input Speed	Backlash	Weight	Design Life
		Nm	Nm	Nm	Nm	r/min	r/min	Arc sec	Kg	Hour
14	50	6.6	23	8.6	43	8000	3500	≤20	0.38	10000
	80	9.6	29	13.5	57			≤20		15000
	100	9.6	34	13.5	66			≤20		15000
17	50	19.8	42	32	86	7000	3500	≤20	0.56	10000
	80	27.5	53	33	108			≤20		15000
	100	30	66	49	134			≤20		15000
	120	30	66	49	107			≤20		15000
20	50	32	69	42	121	6000	3500	≤20	0.76	10000
	80	42	91	58	158			≤20		15000
	100	50	102	61	182			≤20		15000
	120	50	108	61	182			≤20		15000
25	50	48	121	68.5	230	5500	3500	≤20	1.24	10000
	80	78	169	107	315			≤20		15000
	100	84	194	133	381			≤20		15000
	120	84	207	133	376			≤20		15000
32	50	94	267	133	472	4500	3500	≤20	2.6	10000
	80	146	376	206	702			≤20		15000
	100	169	411	267	800			≤20		15000
	120	169	436	267	848			≤20		15000
40	50	169	459	267	848	4000	3000	≤20	5.0	10000
	80	256	641	351	1210			≤20		15000
	100	328	702	460	1334			≤20		15000
	120	363	762	557	1458			≤20		15000
50*	50	363	800	557	1458	3000	2500	≤20	9.5	15000
	80	459	1163	642	2297			≤10		15000
	100	580	1211	823	2545			≤10		15000
	120	654	1334	1005	2545			≤10		15000
58*	50	654	1458	1042	3025	3000	2200	≤10	13.6	15000
	80	678	1828	951	3025			≤10		15000
	100	860	1964	1309	3927			≤10		15000
	120	921	2124	1470	4113			≤10		15000
		160	921	2722	1494	4236	≤10		15000	

* Consult factory

LHSG-II Series Drawings

LHSG-14-XXX-C-II

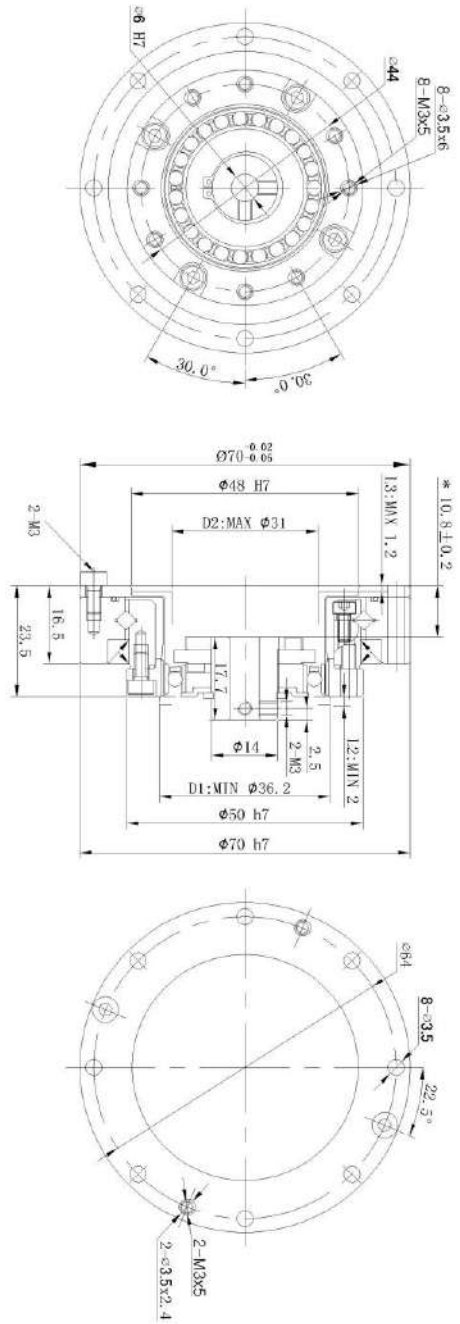

LHSG-17-XXX-C-II

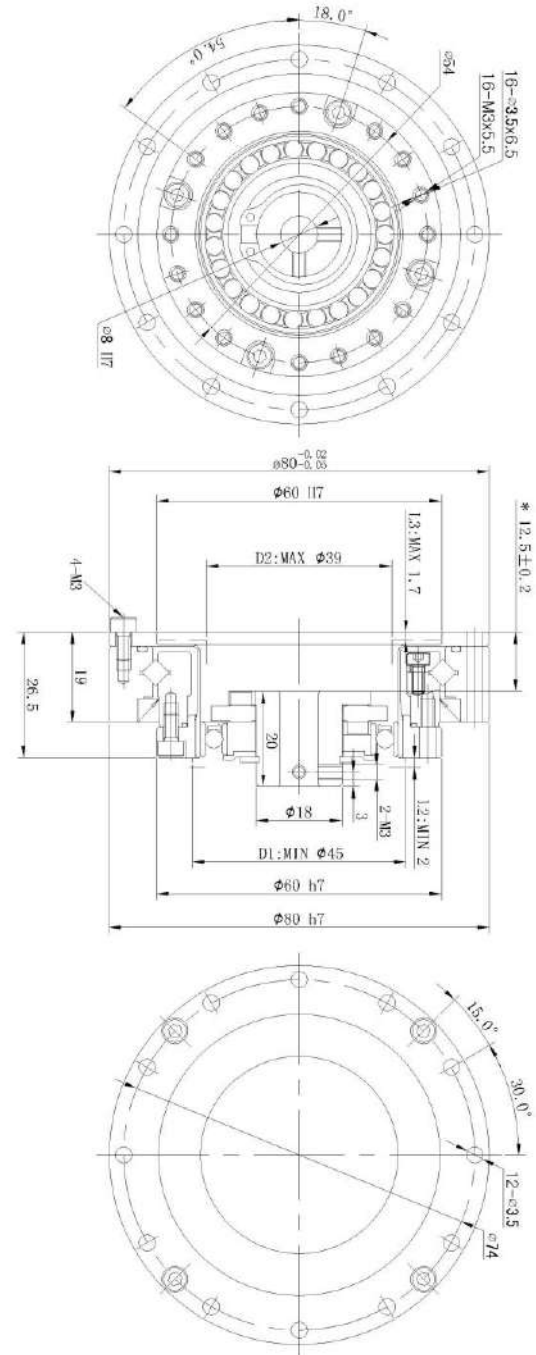

LHSG-II Series Drawings

LHSG-20-XXX-C-II

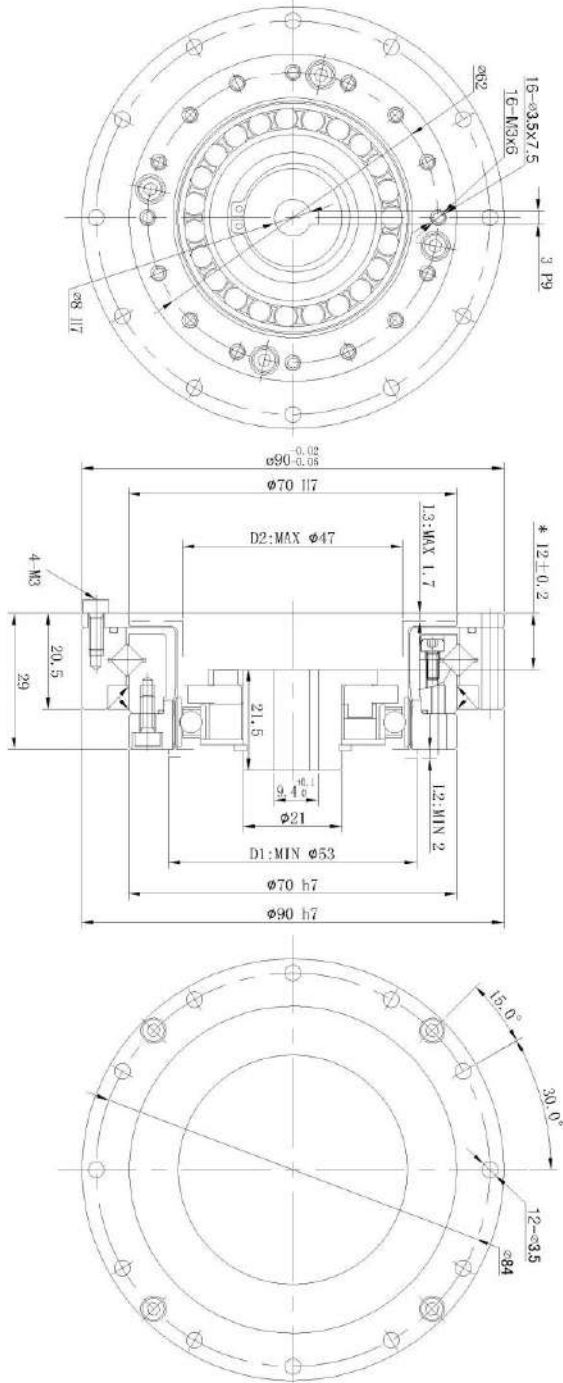

LHSG-25-XXX-C-II

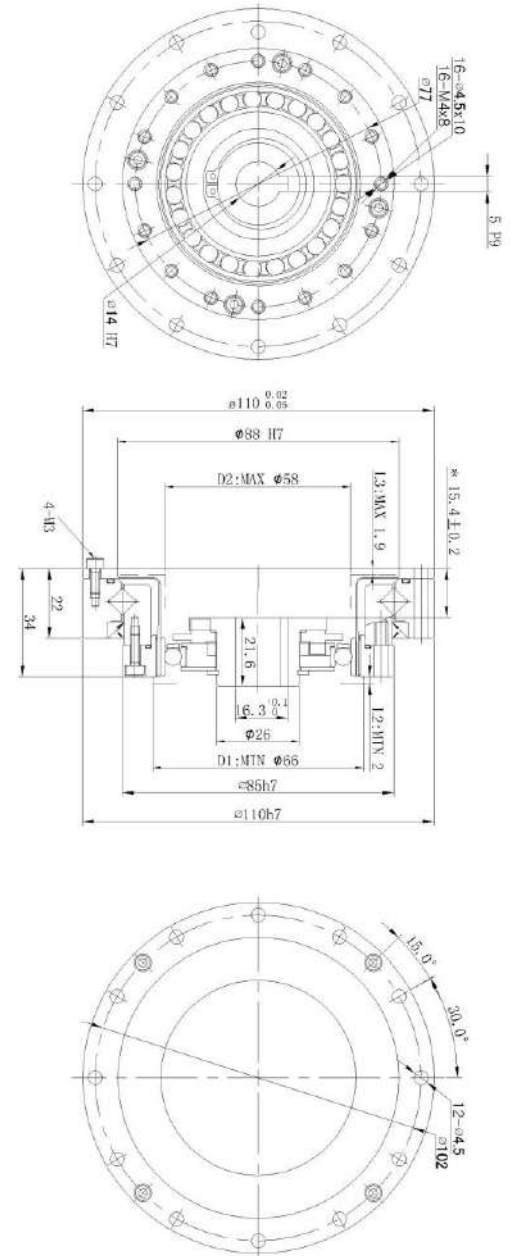

LHSG-III series



LHSG-III series are high-torque models which have the same structure, with LHS-III series. However, their torque bearing capacity is improved by 30% compared with LHS series.

Parameter Table

Item	Reduction Ratio	Rated Torque at 2000r/min	Allowable Peak Torque at Start and Stop	Allowable Average Torque	Allowable Maximum Momentary Torque	Maximum Input Speed	Allowable Average Input Speed	Back lash	With Maximum Tension	Weight	Design Life
Model No		Nm	Nm	Nm	Nm	r/min	r/min	Arc sec	N	Kg	Hour
14	50	6.6	23	8.6	43	8000	3500	≤20	≤77	0.72	10000
	80	9.6	29	13.5	57			≤10			15000
	100	9.6	34	13.5	66			≤10			15000
17	50	19.8	42	32	86	7000	3500	≤20	≤92	1.0	10000
	80	27.5	53	33	108			≤10			15000
	100	30	66	49	134			≤10			15000
20	120	30	66	49	107	6000	3500	≤10	≤136	1.38	15000
	50	32	69	42	121			≤20			10000
	80	42	91	58	158			≤10			15000
25	100	50	102	61	182	5500	3500	≤10	≤147	2.15	15000
	120	50	108	61	182			≤10			15000
	160	50	113	61	182			≤10			15000
32	50	48	121	68.5	230	4500	3500	≤20	≤154	4.3	10000
	80	78	169	107	315			≤10			15000
	100	84	194	133	351			≤10			15000
40	120	84	207	133	376	4000	3000	≤10	≤294	7.8	15000
	160	84	217	133	388			≤10			15000
	50	94	267	133	472			≤20			10000
50*	80	146	376	206	702	3000	2500	≤10	≤373	14.5	15000
	100	169	411	267	800			≤10			15000
	120	169	436	267	848			≤10			15000
58*	160	169	459	267	848	3000	2200	≤10	≤1300	20.0	15000
	50	169	497	242	847			≤10			10000
	80	255	641	351	1210			≤10			15000
50*	100	328	702	460	1334	3000	2500	≤10	≤373	14.5	15000
	120	363	762	557	1458			≤10			15000
	160	363	800	557	1458			≤10			15000
58*	80	459	1163	641	2297	3000	2200	≤10	≤1300	20.0	15000
	100	580	1211	823	2545			≤10			15000
	120	654	1334	1004	2545			≤10			15000
58*	160	654	1458	1041	3025	3000	2200	≤10	≤1300	20.0	15000
	80	678	1828	951	3026			≤10			15000
	100	860	1964	1309	3927			≤10			15000
58*	120	921	2124	1470	4113	3000	2200	≤10	≤1300	20.0	15000
	160	921	2272	1494	4236			≤10			15000

* Consult factory

LHSG-III Series Drawings

LHSG-14-XXX-C-III

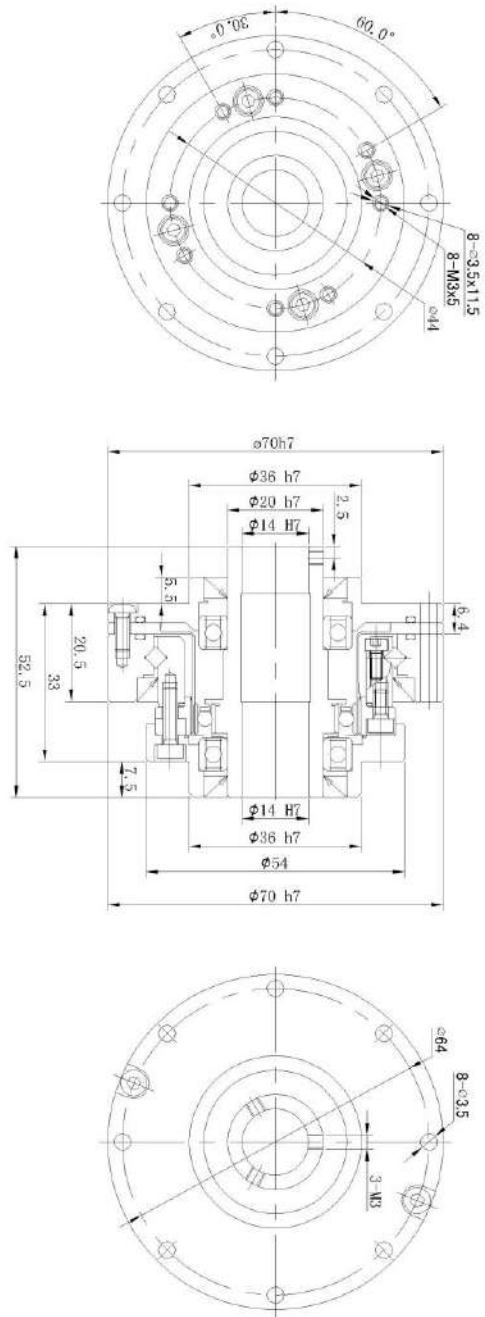

LHSG-14-XXX-C-III-ST

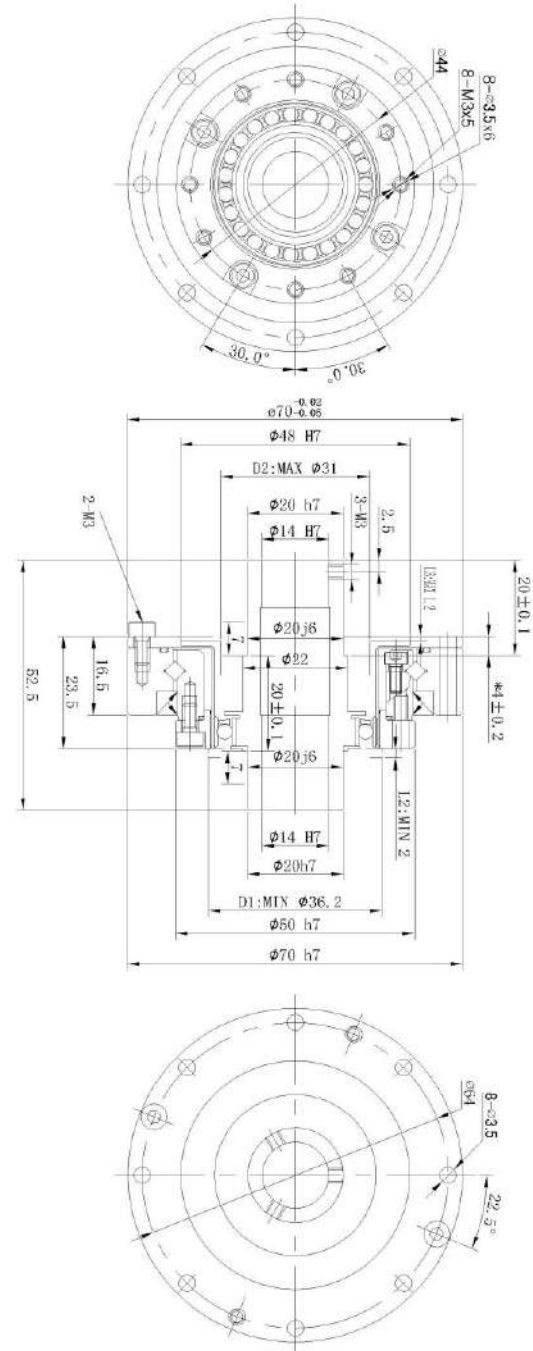

LHSG-III Series Drawings

LHSG-17-XXX-C-III

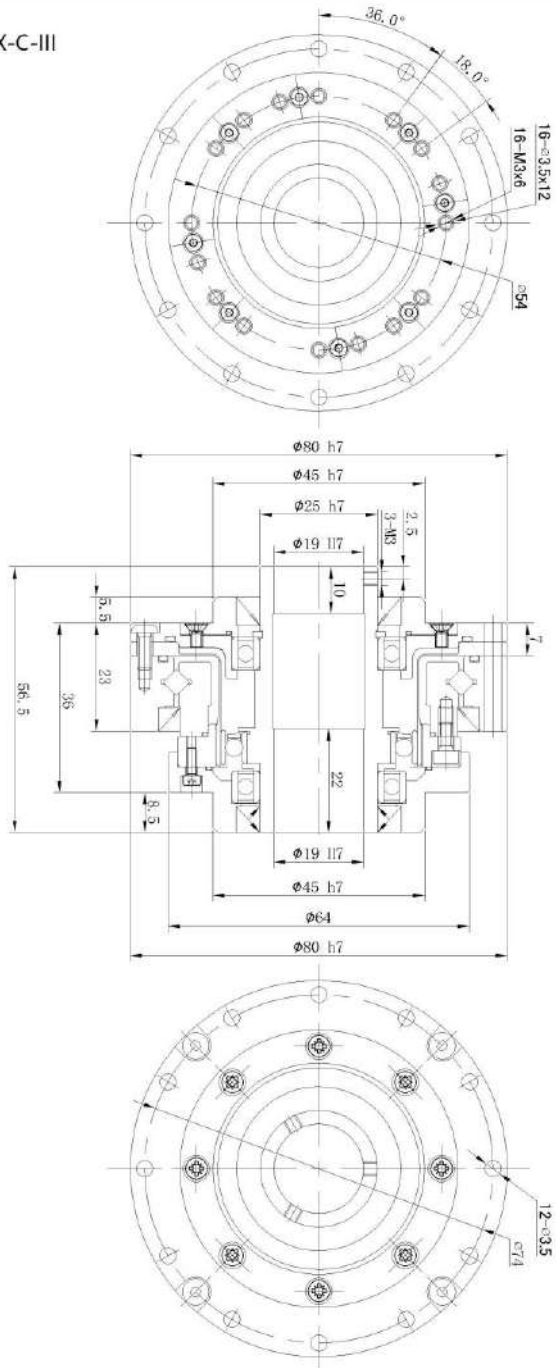

LHSG-17-XXX-C-III-ST

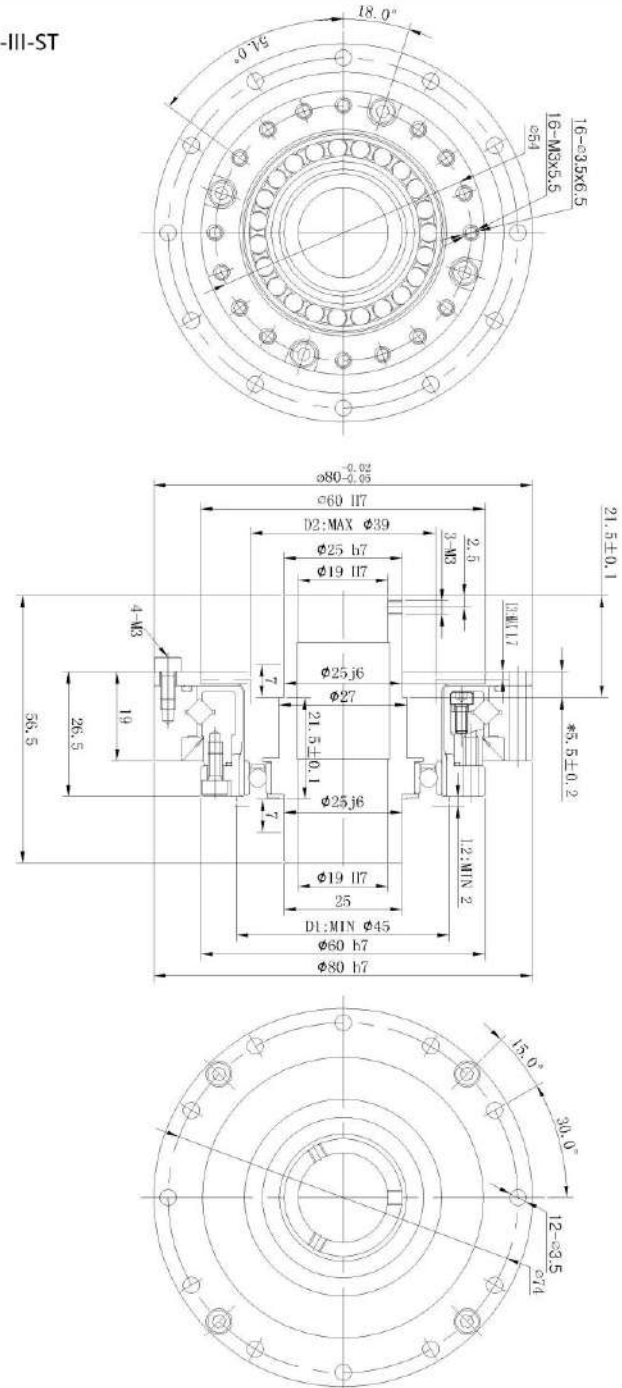

LHSG-III Series Drawings

LHSG-20-XXX-C-III

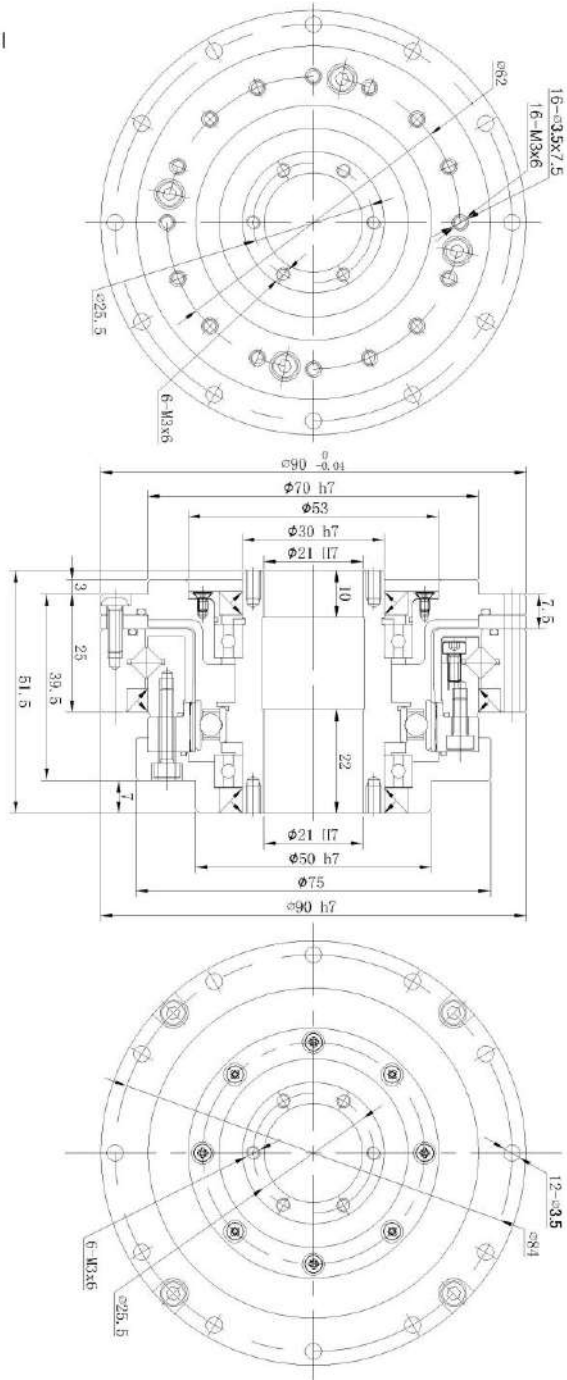

LHSG-20-XXX-C-III-ST

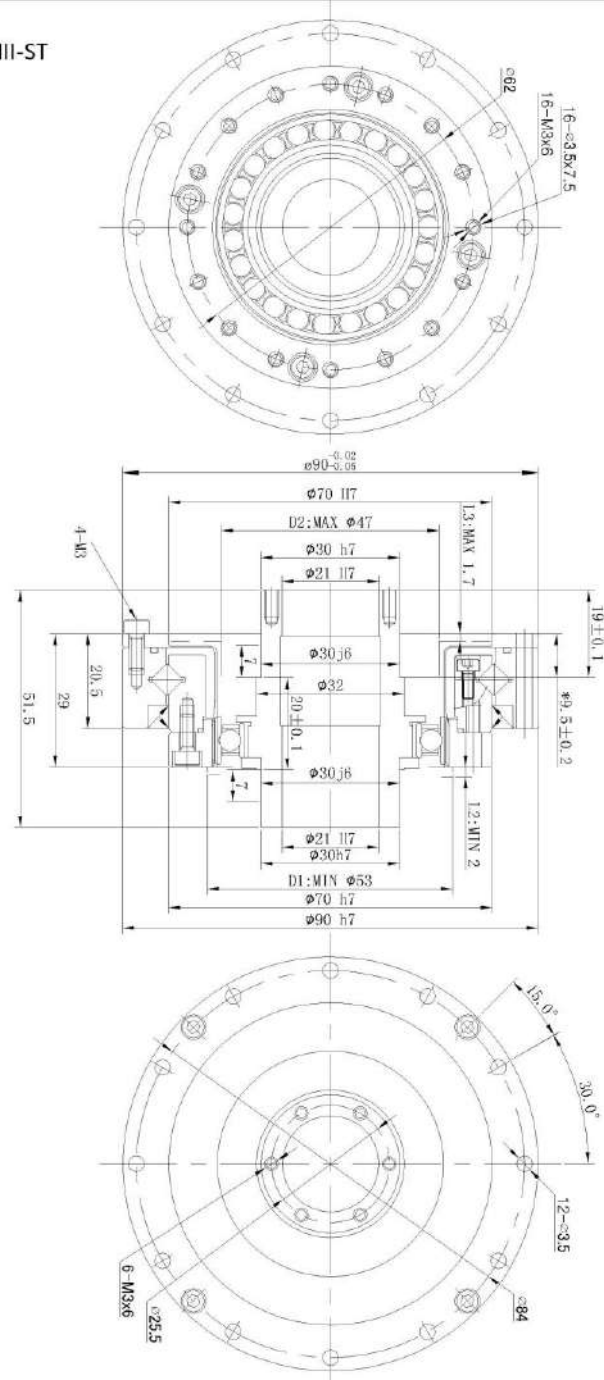

LHSG-III Series Drawings

LHSG-40-XXX-C-III

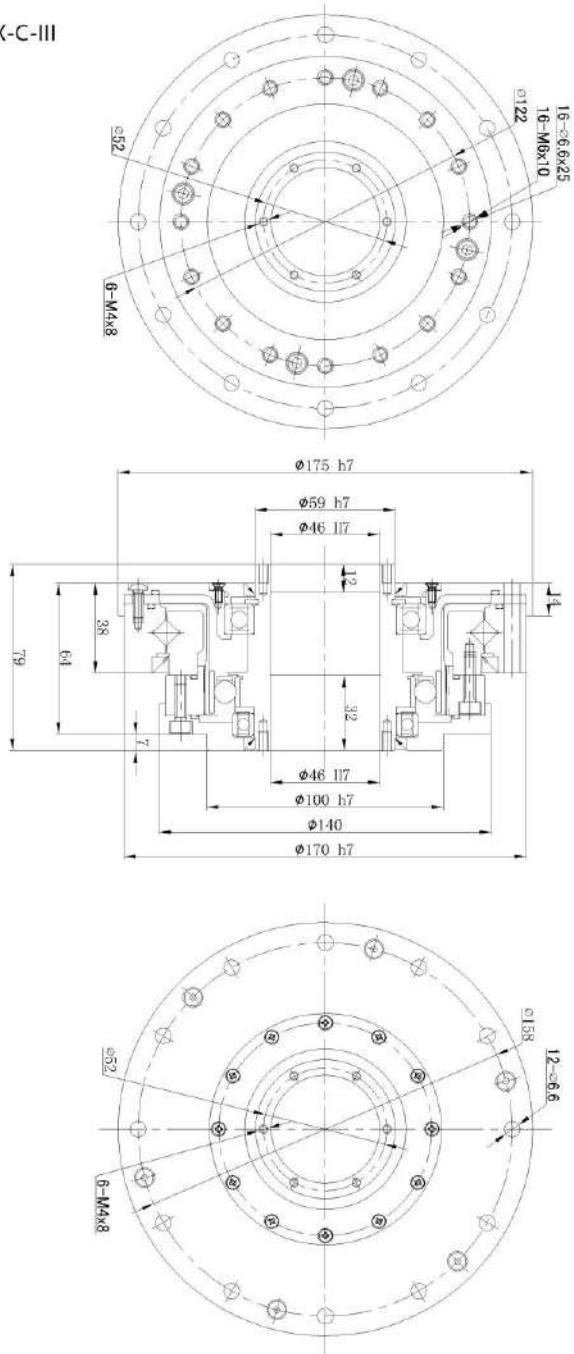

LHSG-40-XXX-C-III-ST

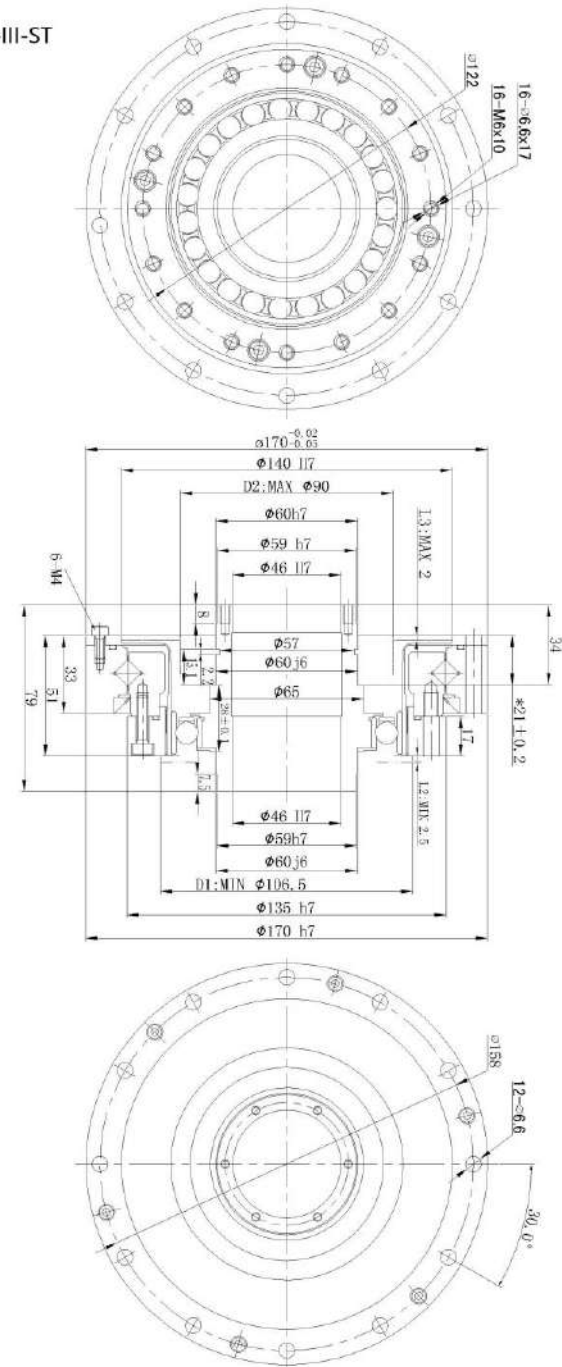

LHSG-III Series Drawings

LHSG-58-XXX-C-III

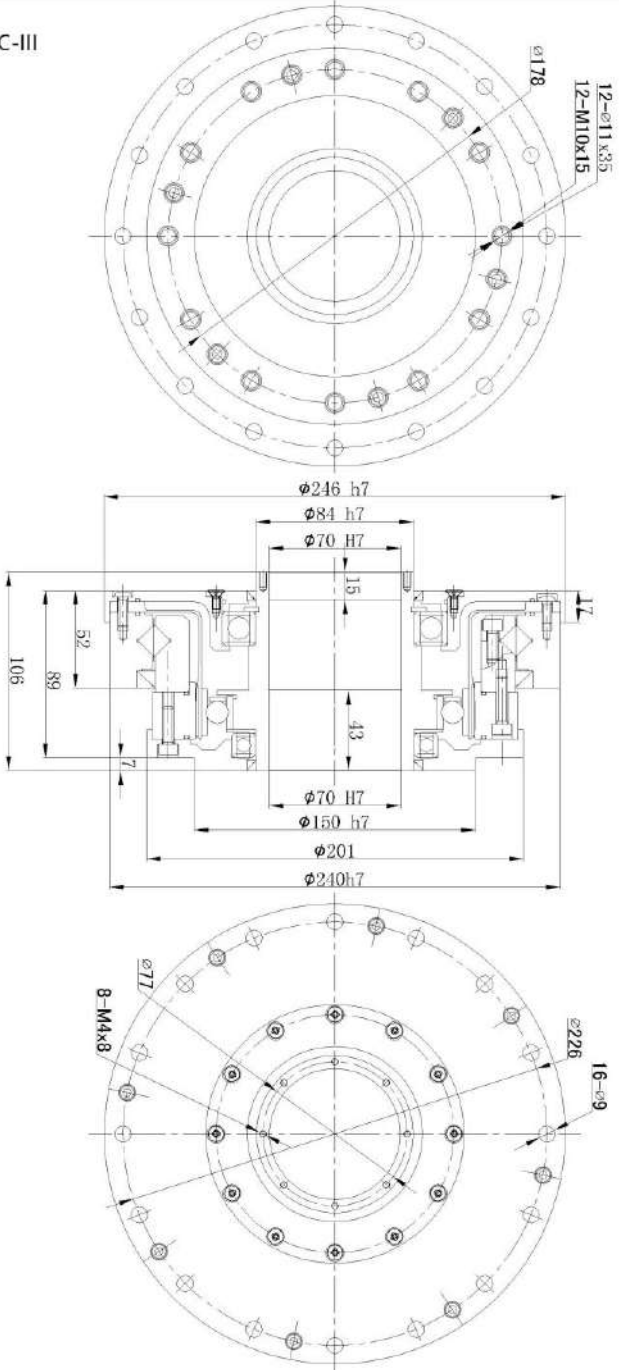

LHSG-CL-III series



LHSG-CL-III series are high-torque models which have the same structure, with LHS-CL-III series. However, their torque bearing capacity is improved by 30% compared with LHS series.

Parameter Table

Item Model No	Reduction Ratio	Rated Torque at 2000r/min	Allowable Peak Torque at Start and Stop	Allowable Average Torque	Allowable Maximum Momentary Torque	Maximum Input Speed	Allowable Average Input Speed	Back lash	With Maximum Tension	Weight	Design Life
		Nm	Nm	Nm	Nm	r/min	r/min	Arc sec	N	Kg	Hour
14	50	6.6	23	8.6	43	8000	3500	≤10	≤77	0.56	10000
	80	9.6	29	13.5	57			≤10			15000
	100	9.6	34	13.5	66			≤10			15000
17	50	19.8	42	32	86	7000	3500	≤10	≤92	0.80	10000
	80	27.5	53	33	108			≤10			15000
	100	30	66	49	134			≤10			15000
	120	30	66	49	107			≤10			15000
20	50	32	69	42	121	6000	3500	≤10	≤136	1.09	10000
	80	42	91	58	168			≤10			15000
	100	50	102	61	182			≤10			15000
	120	50	108	61	182			≤10			15000
	160	50	113	61	182			≤10			15000
25	50	48	121	68.5	230	5500	3500	≤10	≤147	1.70	10000
	80	78	169	107	315			≤10			15000
	100	84	194	133	351			≤10			15000
	120	84	207	133	376			≤10			15000
32	50	94	267	133	472	4500	3500	≤10	≤154	3.50	10000
	80	146	376	206	702			≤10			15000
	100	169	411	267	800			≤10			15000
	120	169	436	267	848			≤10			15000
	160	169	459	267	848			≤10			15000
40	50	169	497	242	847	4000	3000	≤10	≤294	6.35	10000
	80	255	641	351	1210			≤10			15000
	100	328	702	460	1334			≤10			15000
	120	363	762	557	1458			≤10			15000
	160	363	800	557	1458			≤10			15000
50*	80	459	1163	641	2297	3000	2500	≤10	≤373	12.0	15000
	100	580	1211	823	2546			≤10			15000
	120	654	1334	1004	2545			≤10			15000
	160	654	1458	1041	3025			≤10			15000
58*	80	678	1828	951	3026	3000	2200	≤10	≤1300	16.5	15000
	100	860	1954	1309	3927			≤10			15000
	120	921	2124	1470	4113			≤10			15000
	160	921	2272	1494	4236			≤10			15000

* Consult factory

LHSG-CL-III Series Drawings

LHSG-14-XXX-CL-III

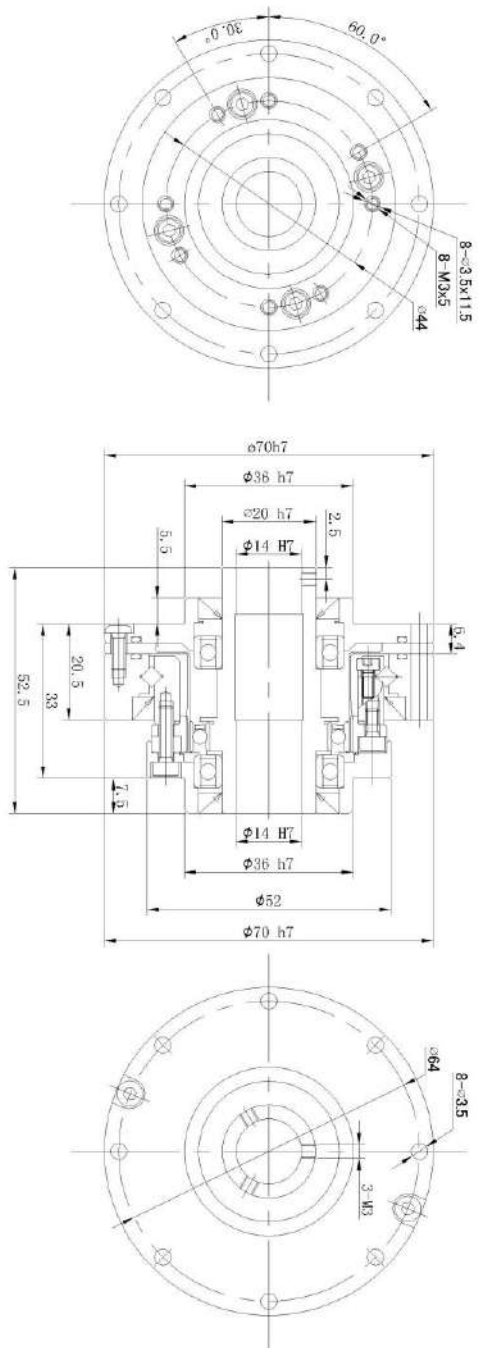

LHSG-17-XXX-CL-III

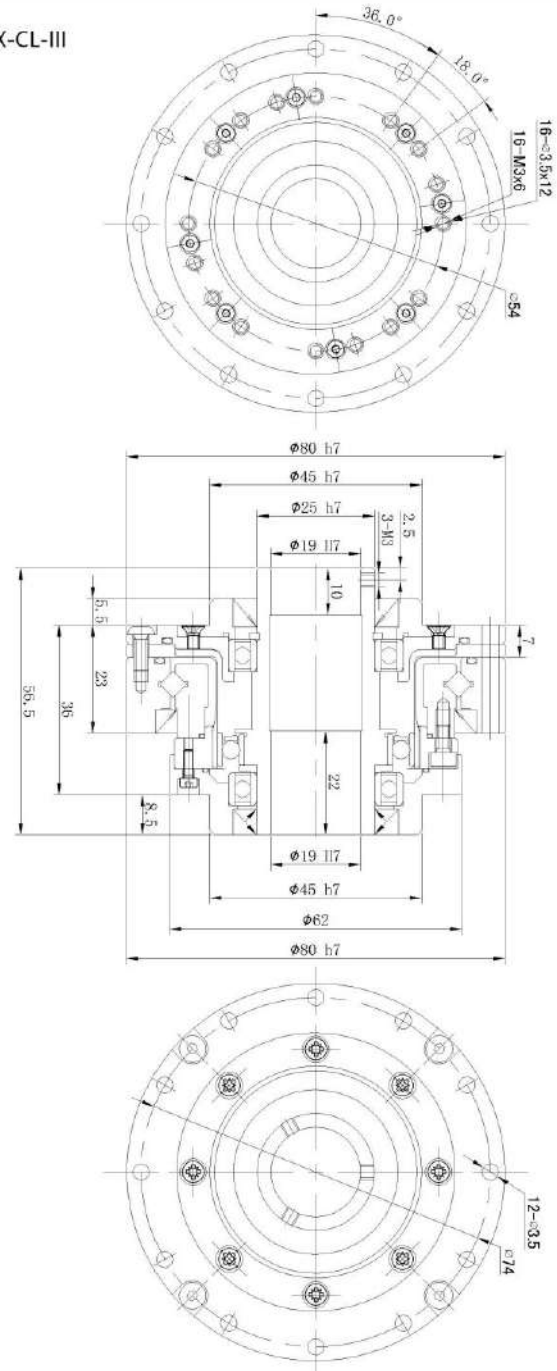

LHSG-CL-III Series Drawings

LHSG-32-XXX-CL-III

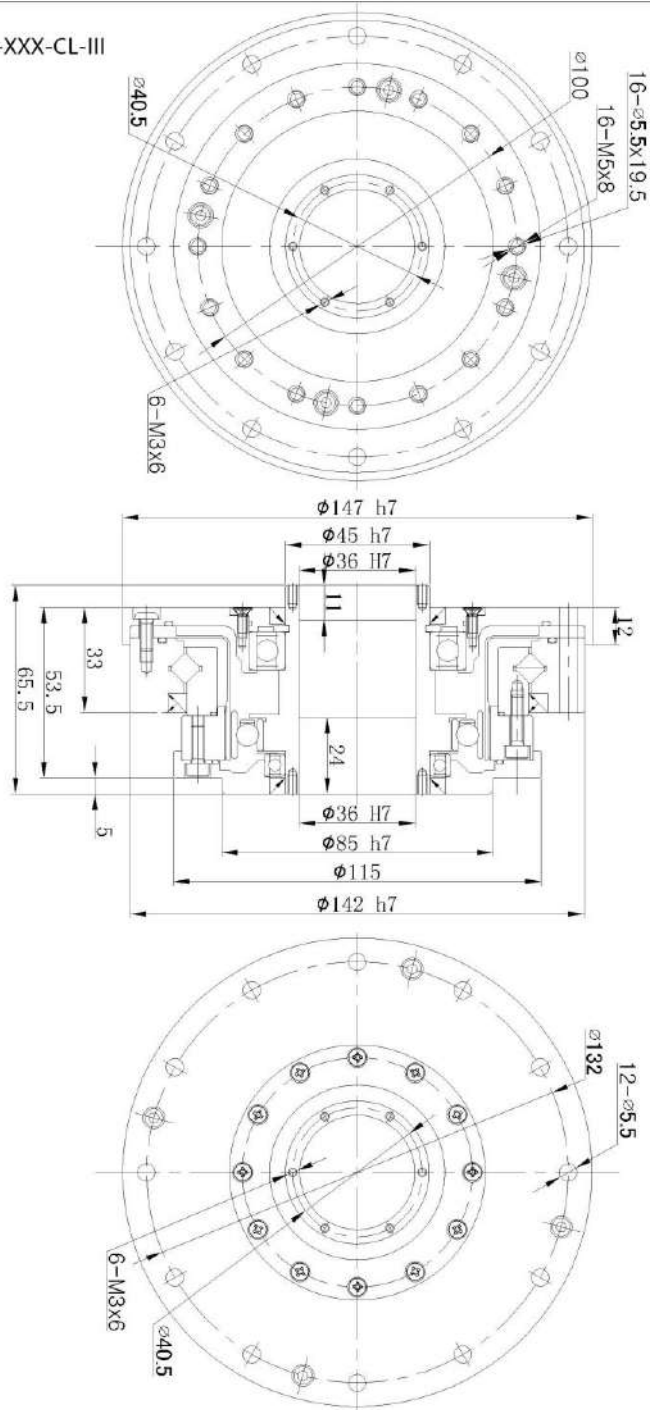

LHSG-40-XXX-CL-III

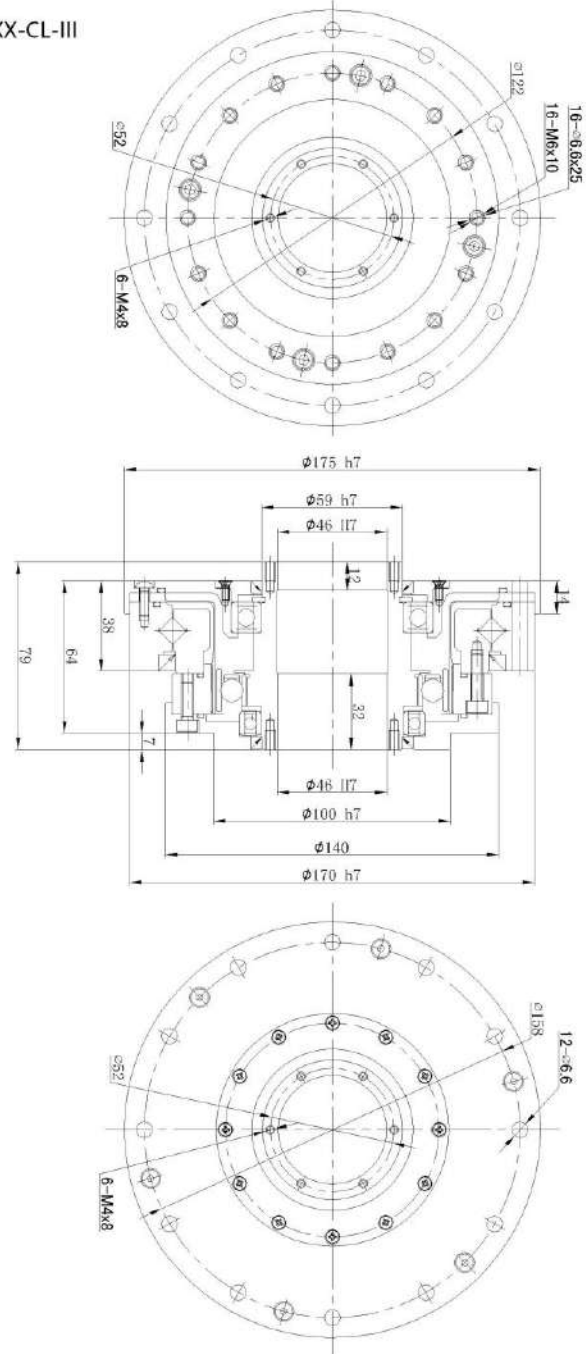

LHSG-IV series



LHSG-IV series are high-torque models which have the same structure, with LHS-IV series. However, their torque bearing capacity is improved by 30% compared with LHS series.

Parameter Table

Item	Reduction Ratio	Rated Torque at 2000r/min	Allowable Peak Torque at Start and Stop	Allowable Average Torque	Allowable Maximum Momentary Torque	Maximum Input Speed	Allowable Average Input Speed	Back lash	With Maximum Torque	Weight	Design Life
		Nm	Nm	Nm	Nm	r/min	r/min	Arc sec	N	Kg	Hour
14	50	6.6	23	8.6	43	8000	3500	≤10	≤26	0.66	10000
	80	9.6	29	13.5	57			≤10			15000
	100	9.6	34	13.5	66			≤10			15000
17	50	19.8	42	32	86	7000	3500	≤10	≤32	0.92	10000
	80	27.5	53	33	108			≤10			15000
	100	30	66	49	134			≤10			15000
	120	30	66	49	107			≤10			15000
20	50	32	69	42	121	6000	3500	≤10	≤58	1.36	10000
	80	42	91	58	158			≤10			15000
	100	50	102	61	182			≤10			15000
	120	50	108	61	182			≤10			15000
	160	50	113	61	182			≤10			15000
25	50	48	121	68.5	230	5500	3500	≤10	≤71	2.05	10000
	80	78	169	107	315			≤10			15000
	100	84	194	133	351			≤10			15000
	120	84	207	133	376			≤10			15000
	160	84	217	133	388			≤10			15000
32	50	94	267	133	472	4500	3500	≤10	≤114	4.35	10000
	80	146	376	206	702			≤10			15000
	100	169	411	267	800			≤10			15000
	120	169	436	267	848			≤10			15000
	160	169	459	267	848			≤10			15000
40	50	169	497	242	847	4000	3000	≤10	≤294	7.9	10000
	80	255	641	351	1210			≤10			15000
	100	328	702	460	1334			≤10			15000
	120	363	762	557	1458			≤10			15000
	160	363	800	557	1458			≤10			15000

LHSG-IV Series Drawings

LHSG-14-XXX-C-IV

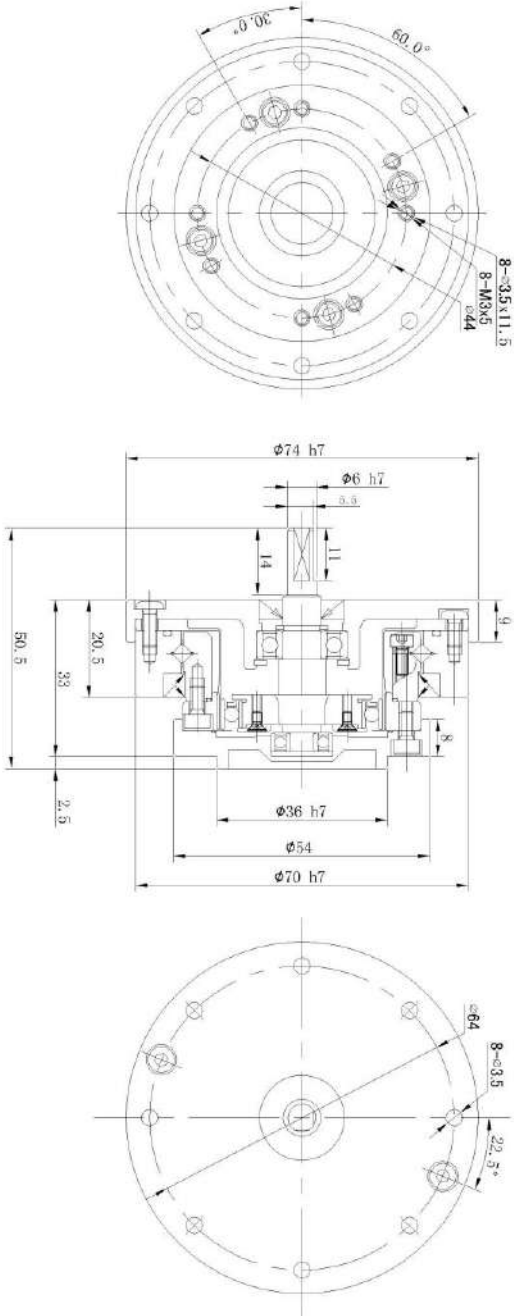

LHSG-17-XXX-C-IV

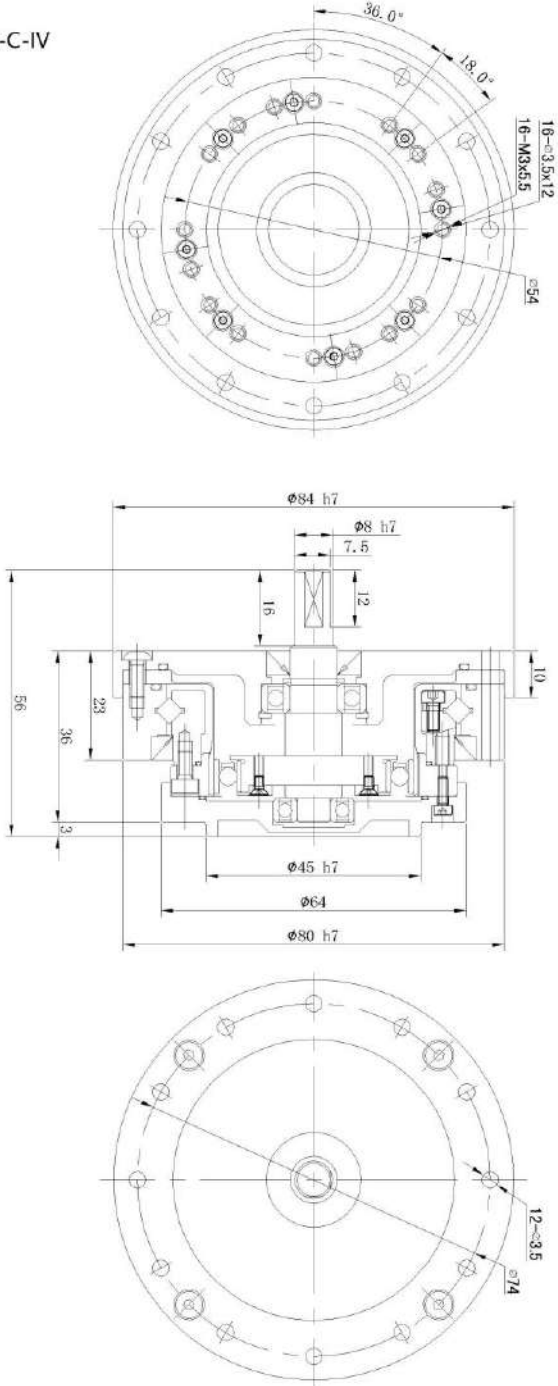

LHSG-IV Series Drawings

LHSG-20-XXX-C-IV

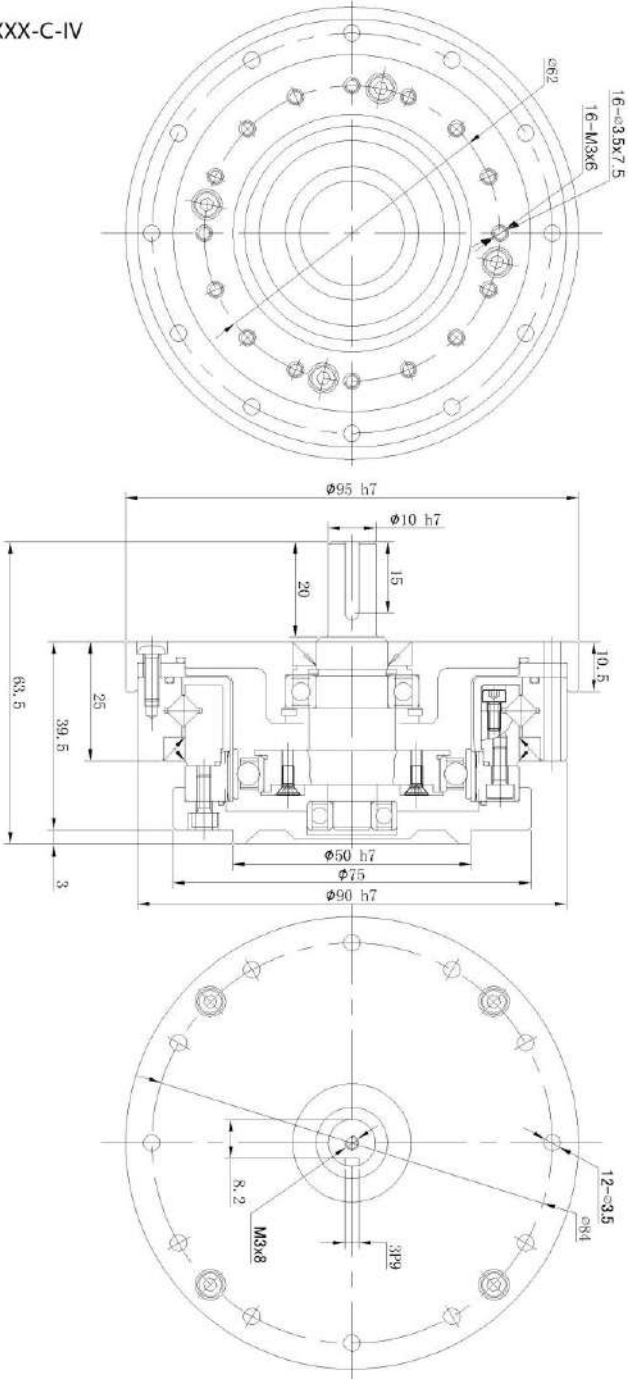

LHSG-25-XXX-C-IV

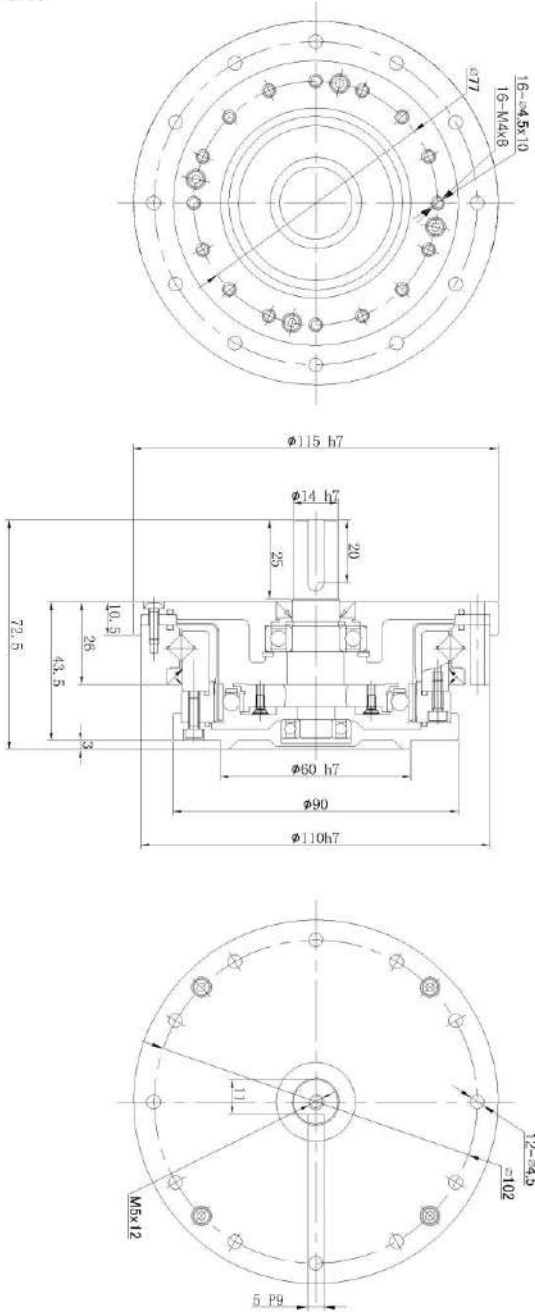

LHSG-IV Series Drawings

LHSG-32-XXX-C-IV

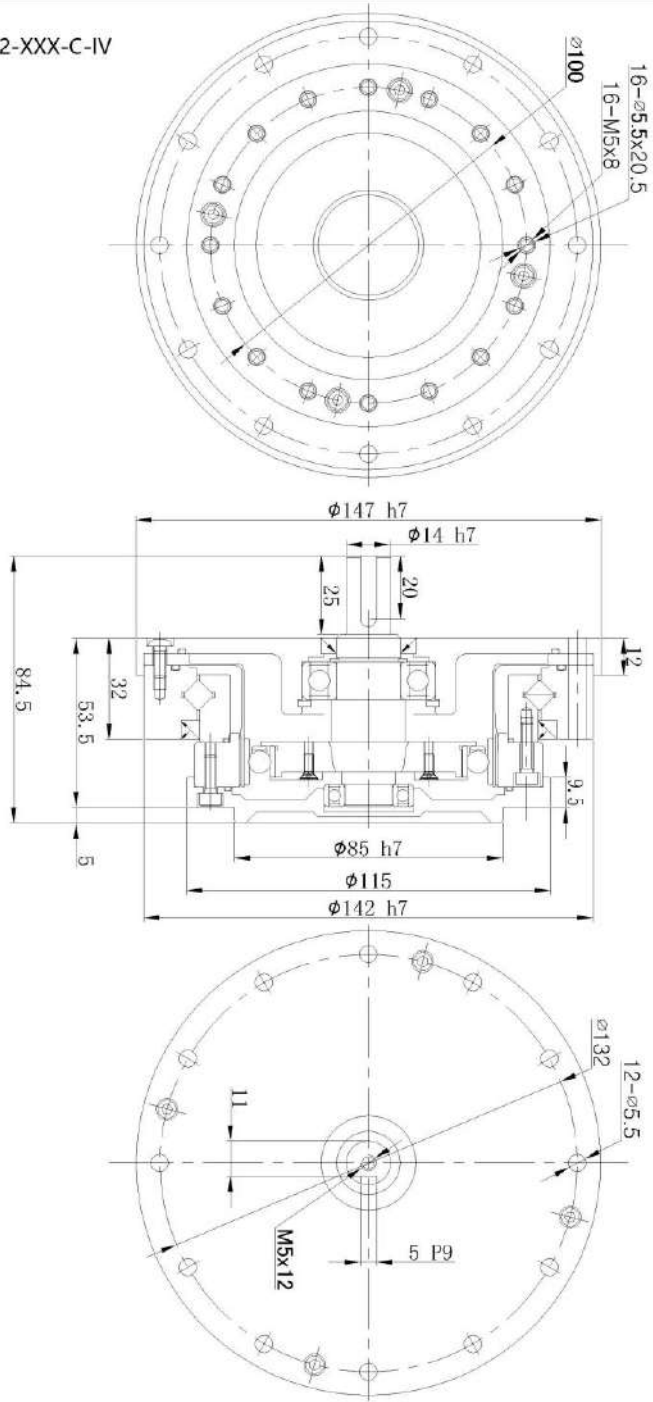

LHSG-40-XXX-C-IV

