

混合式步进电机规格书 HYBRID STEPPING MOTOR SPECIFICATION

版本 REV.	位置 LOC.	变更号 ECN NO.	变更内容 REVISION RECORD	日期 DATE	设计 BY

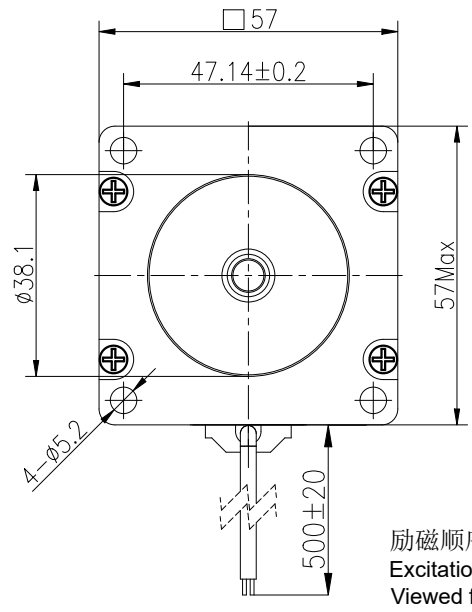

电机接线 Motor Wiring Diagram

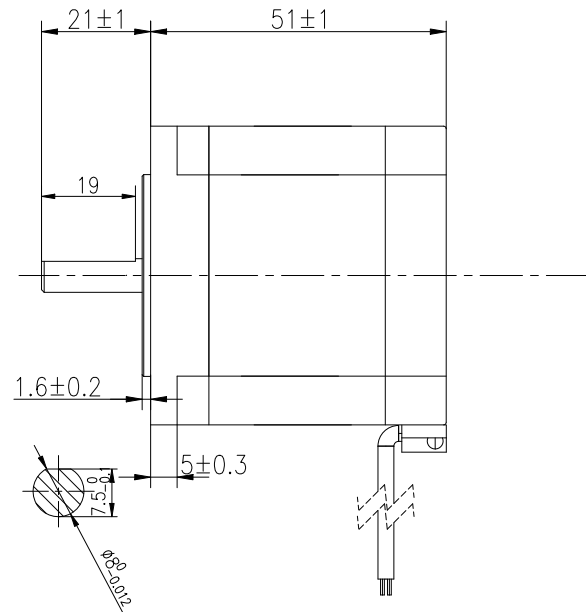
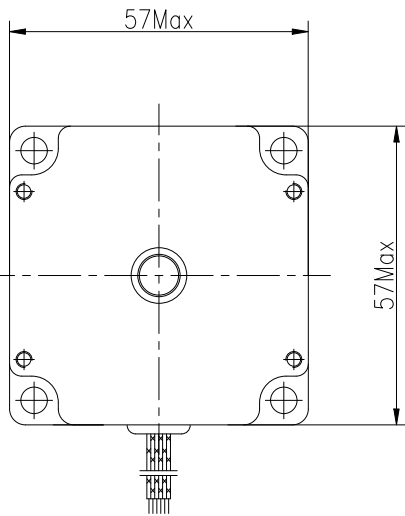
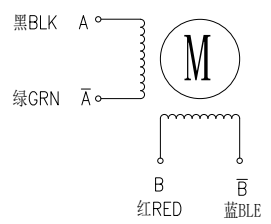

励磁顺序&旋转方向 从电机的安装面看
Excitation sequence & direction of rotation
Viewed from the mounting surface of the motor

STEP	A	B	Ā	B̄	CCW
黑 BLK	+	+	-	-	↑ ↓
绿 GRN	-	+	+	-	
红 RED	-	-	+	+	
蓝 BLE	+	-	-	+	

电机相数/Phase	2
步距角/Step Angle	1.8°
额定电流/Rated current	1.5A
电阻/Resistance	5.0Ω ±10%
电感/Inductance	13mH ±20%
静扭矩/Holding Torque	0.7N.m
绝缘耐压/Dielectric strength	500VAC/1min
绝缘电阻/Insulation Resistance	100MΩMin/500VDC
转动惯量/Moment of inertia	23.7kg.mm ²
温升/Temperature rise	80°C
电机重量/Motor mass	0.65kg
绝缘等级/Insulation class	B
防护等级/Protective enclosure rating	IP54

CTQ Sign: Customer; Process; Law	名称 NAMES	签名 SIGNATURE	日期 DATE	名称 TITLE	STEPPING MOTOR
物料符合RoHS指令要求 All Material are to be RoHS Compliant	设计 DESIGN			型号 MODEL	57HB51F105-08B
UNLESS OTHERWISE SPECIFIED	标准化 STANDARD			图号 DWG.NO.	
单位 Unit:mm <=6 ±0.1 >6-30 ±0.2 >30~120 ±0.3 ISO 2768-1 class m >120-400 ±0.5	工艺 TECHNOLOGY			日期 DATE	2025.05.02
1.未注线性公差参照 GB/T1804-m级 ISO 2768-1 class m	审核 CHECK			材料 MATERIAL	
2.常规公差Tolerances: 角度 Angles:±0.1° 倒角 Chamfer:±5°	批准 APPROVE			图幅 SIZE	版本 REV. 页 SHEET 比例 SCALE
CHANGZHOU HOLRY ELECTRIC TECHNOLOGY CO.,LTD.	第一角画法 FIRST ANGLE METHOD	客户型号 CUSTOMER'S MODEL.NO.	版本 REV.		
	变更标识 ECN SIGN				